

WinTech 

GHD

Indexable Drills Catalog - 2016.2

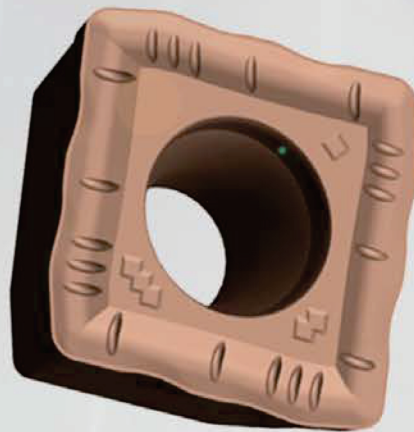



● 可转位浅孔钻命名规则 Identification of Indexable Drills

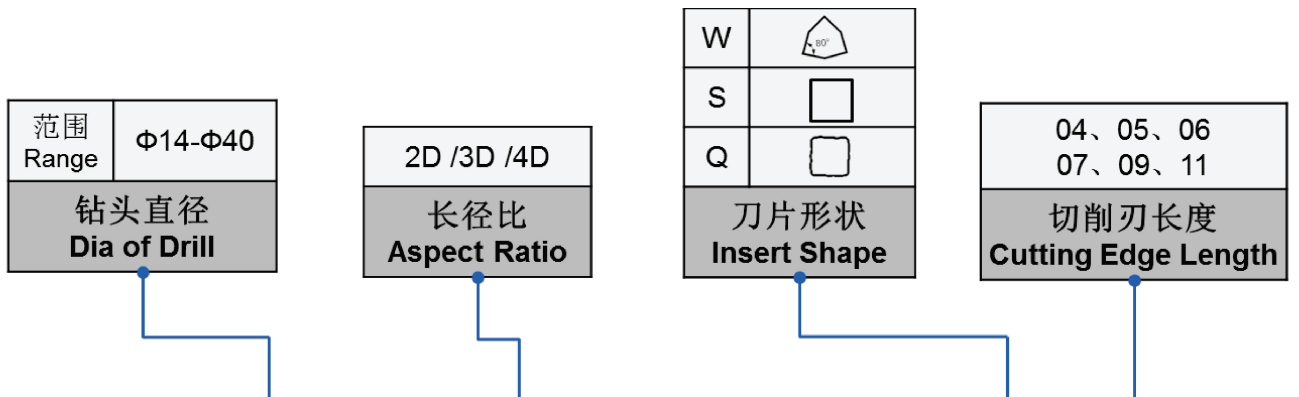

GHD - 200 - 3D - FC 25 - Q 06 A

| 刀具类型 Tool Type | |
|-------------------|----------------------------|
| GHD | 可转位浅孔钻 Indexable Drills |

| 刀柄类型 Shank Type | |
|--------------------|----------------------------|
| FC | 法兰—平面侧固式 Flange—Plat |
| FW | 法兰—韦尔登式 Flange—Weldone |
| FH | 法兰—惠氏哨口式 Flange—Whistle |
| PC | 直柄—平面侧固式 Pillar—Plat |
| PW | 直柄—韦尔登式 Pillar—Weldone |
| PH | 直柄—惠氏哨口式 Pillar—Whistle |

| 刀柄直径 Shank Size | |
|--------------------|-----|
| Φ20 | Φ25 |
| Φ32 | Φ40 |

| 钻头类型 Drilling Type | |
|-----------------------|---------------------|
| A | 常规 General |
| D | 客户定制 Custom make |



● **GHD 可转位浅孔钻** GHD Indexable Drills



【特点】 Features

- 四条切削刃，经济性好
- Four cutting edges, better economy
- 拳形切削刃设计，拥有专利保护
- Fist edge design with patent protection
- 内外刀片共用，管理、使用方便
- Both the central and the outside inserts are the same, more convenient for management
- 适合多种材质加工，通用性好
- Fitting for various materials



【刀片规格】 Insert List

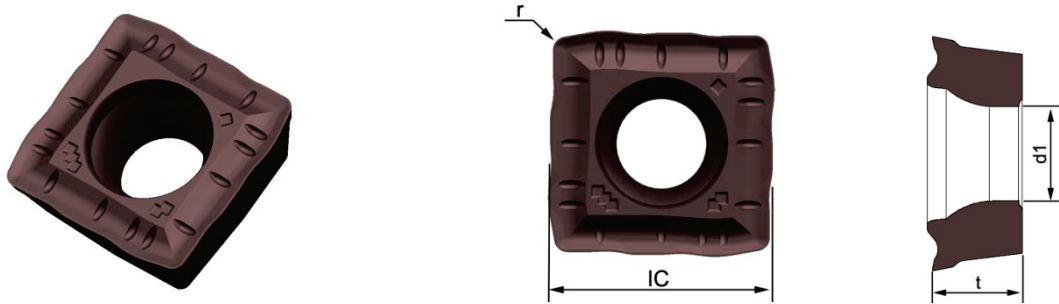

| 型号 Type | 牌号 Grade | 尺寸 (Dimension) | | | | 钻孔直径 Dia of Drill | 库存 Stock |
|---------------|-------------|----------------|------|-----|------|----------------------|-------------|
| | | IC | t | r | d1 | | |
| QPMG040204-DP | A4230 | 4.7 | 2.3 | 0.4 | 2.2 | Φ 14.0 ~ Φ 15.9 | ● |
| QPMG050204-DP | A4230 | 5.7 | 2.5 | 0.4 | 2.6 | Φ 16.0 ~ Φ 18.9 | ● |
| QPMG060204-DP | A4230 | 6.5 | 2.5 | 0.4 | 2.6 | Φ 19.0 ~ Φ 22.5 | ● |
| QPMG07T306-DP | A4230 | 7.94 | 3.2 | 0.6 | 2.85 | Φ 22.6 ~ Φ 27.0 | ● |
| QPMG09T308-DP | A4230 | 9.7 | 3.5 | 0.8 | 3.5 | Φ 27.1 ~ Φ 33.0 | ● |
| QPMG110408-DP | A4230 | 11.5 | 4.76 | 0.8 | 4.4 | Φ 33.1 ~ Φ 40.0 | ● |

● 标准库存 Stock ○ 需预定 Order



● GHD-2D

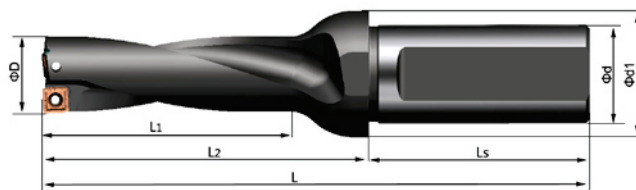

| 直径 Dia | 钻头型号 Type | 尺寸 (Dimension) | | | | | | | 库存 Stock | 刀片 Insert |
|-----------|----------------------|----------------|-----|-------|-------|-------|-------|-----|-------------|--------------|
| | | D | d | d_1 | L_s | L_2 | L_1 | L | | |
| Φ 14 | GHD-140-2D-FC20-Q04A | 14 | 20 | 25 | 50 | 46 | 30 | 96 | ● | QPMG040204 |
| Φ 15 | GHD-150-2D-FC20-Q04A | 15 | 20 | 25 | 50 | 50 | 32 | 100 | ● | |
| Φ 16 | GHD-160-2D-FC20-Q05A | 16 | 20 | 25 | 50 | 52 | 34 | 102 | ● | QPMG050204 |
| Φ 17 | GHD-170-2D-FC25-Q05A | 17 | 25 | 32 | 56 | 54 | 36 | 110 | ● | |
| Φ 18 | GHD-180-2D-FC25-Q05A | 18 | 25 | 32 | 56 | 59 | 39 | 115 | ● | QPMG060204 |
| Φ 19 | GHD-190-2D-FC25-Q06A | 19 | 25 | 32 | 56 | 61 | 41 | 117 | ● | |
| Φ 20 | GHD-200-2D-FC25-Q06A | 20 | 25 | 32 | 56 | 63 | 43 | 119 | ● | QPMG07T306 |
| Φ 21 | GHD-210-2D-FC25-Q06A | 21 | 25 | 32 | 56 | 65 | 45 | 121 | ● | |
| Φ 22 | GHD-220-2D-FC25-Q06A | 22 | 25 | 32 | 56 | 67 | 47 | 123 | ● | QPMG09T308 |
| Φ 23 | GHD-230-2D-FC25-Q07A | 23 | 25 | 32 | 56 | 69 | 49 | 125 | ● | |
| Φ 24 | GHD-240-2D-FC25-Q07A | 24 | 25 | 32 | 56 | 71 | 51 | 127 | ● | QPMG110408 |
| Φ 25 | GHD-250-2D-FC25-Q07A | 25 | 25 | 32 | 56 | 73 | 53 | 129 | ● | |
| Φ 26 | GHD-260-2D-FC32-Q07A | 26 | 32 | 42 | 60 | 81 | 56 | 141 | ● | QPMG09T308 |
| Φ 27 | GHD-270-2D-FC32-Q07A | 27 | 32 | 42 | 60 | 83 | 58 | 143 | ● | |
| Φ 28 | GHD-280-2D-FC32-Q09A | 28 | 32 | 42 | 60 | 85 | 60 | 145 | ● | QPMG110408 |
| Φ 29 | GHD-290-2D-FC32-Q09A | 29 | 32 | 42 | 60 | 87 | 62 | 147 | ● | |
| Φ 30 | GHD-300-2D-FC32-Q09A | 30 | 32 | 42 | 60 | 89 | 64 | 149 | ● | QPMG110408 |
| Φ 31 | GHD-310-2D-FC32-Q09A | 31 | 32 | 42 | 60 | 91 | 66 | 151 | ● | |
| Φ 32 | GHD-320-2D-FC32-Q09A | 32 | 32 | 42 | 60 | 93 | 68 | 153 | ● | QPMG110408 |
| Φ 33 | GHD-330-2D-FC40-Q09A | 33 | 40 | 42 | 60 | 95 | 70 | 155 | ● | |
| Φ 34 | GHD-340-2D-FC40-Q11A | 34 | 40 | 48 | 70 | 101 | 73 | 171 | ● | QPMG110408 |
| Φ 35 | GHD-350-2D-FC40-Q11A | 35 | 40 | 48 | 70 | 103 | 75 | 173 | ● | |
| Φ 36 | GHD-360-2D-FC40-Q11A | 36 | 40 | 48 | 70 | 105 | 77 | 175 | ● | QPMG110408 |
| Φ 37 | GHD-370-2D-FC40-Q11A | 37 | 40 | 48 | 70 | 107 | 79 | 177 | ● | |
| Φ 38 | GHD-380-2D-FC40-Q11A | 38 | 40 | 48 | 70 | 109 | 81 | 179 | ● | QPMG110408 |
| Φ 39 | GHD-390-2D-FC40-Q11A | 39 | 40 | 48 | 70 | 111 | 83 | 181 | ● | |
| Φ 40 | GHD-400-2D-FC40-Q11A | 40 | 40 | 48 | 70 | 113 | 85 | 183 | ● | QPMG110408 |

●标准库存 Stock ○需预定 Order



● GHD-3D

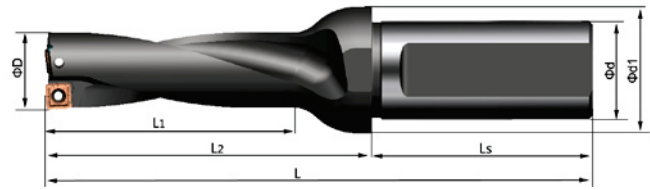

| 直径 Dia | 钻头型号 Type | 尺寸 (Dimension) | | | | | | | 库存 Stock | 刀片 Insert |
|-----------|----------------------|----------------|----|----------------|----------------|----------------|----------------|-----|-------------|--------------|
| | | D | d | d ₁ | L _s | L ₂ | L ₁ | L | | |
| Φ 14.0 | GHD-140-3D-FC20-Q04A | 14.0 | 20 | 25 | 50 | 60 | 44 | 110 | ● | QPMG040204 |
| Φ 14.5 | GHD-145-3D-FC20-Q04A | 14.5 | 20 | 25 | 50 | 62 | 46 | 112 | ● | |
| Φ 15.0 | GHD-150-3D-FC20-Q04A | 15.0 | 20 | 25 | 50 | 65 | 47 | 115 | ● | |
| Φ 15.5 | GHD-155-3D-FC20-Q04A | 15.5 | 20 | 25 | 50 | 67 | 49 | 117 | ● | |
| Φ 16.0 | GHD-160-3D-FC20-Q05A | 16.0 | 20 | 25 | 50 | 68 | 50 | 118 | ● | QPMG050204 |
| Φ 17.0 | GHD-170-3D-FC25-Q05A | 17.0 | 25 | 32 | 56 | 71 | 53 | 127 | ● | |
| Φ 17.5 | GHD-175-3D-FC25-Q05A | 17.5 | 25 | 32 | 56 | 73 | 55 | 129 | ● | |
| Φ 18.0 | GHD-180-3D-FC25-Q05A | 18.0 | 25 | 32 | 56 | 77 | 57 | 133 | ● | |
| Φ 18.5 | GHD-185-3D-FC25-Q05A | 18.5 | 25 | 32 | 56 | 79 | 59 | 135 | ● | QPMG060204 |
| Φ 19.0 | GHD-190-3D-FC25-Q06A | 19.0 | 25 | 32 | 56 | 80 | 60 | 136 | ● | |
| Φ 19.5 | GHD-195-3D-FC25-Q06A | 19.5 | 25 | 32 | 56 | 82 | 62 | 138 | ● | |
| Φ 20.0 | GHD-200-3D-FC25-Q06A | 20.0 | 25 | 32 | 56 | 83 | 63 | 139 | ● | |
| Φ 20.5 | GHD-205-3D-FC25-Q06A | 20.5 | 25 | 32 | 56 | 85 | 65 | 141 | ● | QPMG07T306 |
| Φ 21.0 | GHD-210-3D-FC25-Q06A | 21.0 | 25 | 32 | 56 | 86 | 66 | 142 | ● | |
| Φ 21.5 | GHD-215-3D-FC25-Q06A | 21.5 | 25 | 32 | 56 | 88 | 68 | 144 | ● | |
| Φ 22.0 | GHD-220-3D-FC25-Q06A | 22.0 | 25 | 32 | 56 | 89 | 69 | 145 | ● | |
| Φ 22.5 | GHD-225-3D-FC25-Q06A | 22.5 | 25 | 32 | 56 | 91 | 71 | 147 | ● | QPMG09T308 |
| Φ 23.0 | GHD-230-3D-FC25-Q07A | 23.0 | 25 | 32 | 56 | 92 | 72 | 148 | ● | |
| Φ 23.5 | GHD-235-3D-FC25-Q07A | 23.5 | 25 | 32 | 56 | 92 | 74 | 150 | ● | |
| Φ 24.0 | GHD-240-3D-FC25-Q07A | 24.0 | 25 | 32 | 56 | 95 | 75 | 151 | ● | |
| Φ 24.5 | GHD-245-3D-FC25-Q07A | 24.5 | 25 | 32 | 56 | 97 | 77 | 153 | ● | QPMG09T308 |
| Φ 25.0 | GHD-250-3D-FC25-Q07A | 25.0 | 25 | 32 | 56 | 98 | 78 | 154 | ● | |
| Φ 25.5 | GHD-255-3D-FC32-Q07A | 25.5 | 32 | 42 | 60 | 106 | 81 | 166 | ● | |
| Φ 26.0 | GHD-260-3D-FC32-Q07A | 26.0 | 32 | 42 | 60 | 107 | 82 | 167 | ● | |
| Φ 26.5 | GHD-265-3D-FC32-Q07A | 26.5 | 32 | 42 | 60 | 109 | 84 | 169 | ● | QPMG09T308 |
| Φ 27.0 | GHD-270-3D-FC32-Q07A | 27.0 | 32 | 42 | 60 | 110 | 85 | 170 | ● | |
| Φ 28.0 | GHD-280-3D-FC32-Q09A | 28.0 | 32 | 42 | 60 | 113 | 88 | 173 | ● | |
| Φ 29.0 | GHD-290-3D-FC32-Q09A | 29.0 | 32 | 42 | 60 | 116 | 91 | 176 | ● | |



| | | | | | | | | | | |
|--------|----------------------|------|----|----|----|-----|-----|-----|---|------------|
| Φ 30.0 | GHD-300-3D-FC32-Q09A | 30.0 | 32 | 42 | 60 | 119 | 94 | 179 | ● | |
| Φ 31.0 | GHD-310-3D-FC32-Q09A | 31.0 | 32 | 42 | 60 | 122 | 97 | 182 | ● | |
| Φ 31.5 | GHD-315-3D-FC32-Q09A | 31.5 | 32 | 42 | 60 | 124 | 99 | 184 | ● | |
| Φ 32.0 | GHD-320-3D-FC32-Q09A | 32.0 | 32 | 42 | 60 | 125 | 100 | 185 | ● | |
| Φ 33.0 | GHD-330-3D-FC32-Q09A | 33.0 | 32 | 42 | 60 | 128 | 103 | 188 | ● | |
| Φ 34.0 | GHD-340-3D-FC40-Q11A | 34.0 | 40 | 48 | 70 | 135 | 107 | 205 | ● | QPMG110408 |
| Φ 35.0 | GHD-350-3D-FC40-Q11A | 35.0 | 40 | 48 | 70 | 138 | 110 | 208 | ● | |
| Φ 36.0 | GHD-360-3D-FC40-Q11A | 36.0 | 40 | 48 | 70 | 141 | 113 | 211 | ● | |
| Φ 37.0 | GHD-370-3D-FC40-Q11A | 37.0 | 40 | 48 | 70 | 144 | 116 | 214 | ● | |
| Φ 38.0 | GHD-380-3D-FC40-Q11A | 38.0 | 40 | 48 | 70 | 147 | 119 | 217 | ● | |
| Φ 39.0 | GHD-390-3D-FC40-Q11A | 39.0 | 40 | 48 | 70 | 150 | 122 | 220 | ● | |
| Φ 40.0 | GHD-400-3D-FC40-Q11A | 40.0 | 40 | 48 | 70 | 153 | 125 | 223 | ● | |

●标准库存 Stock ○需预定 Order



● GHD-4D

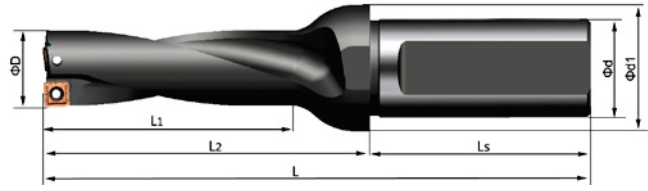

| 直径 Dia | 钻头型号 Type | 尺寸 (Dimension) | | | | | | | 库存 Stock | 刀片 Insert |
|-----------|----------------------|----------------|-----|-------|-------|-------|-------|-----|-------------|--------------|
| | | D | d | d_1 | L_s | L_2 | L_1 | L | | |
| Φ 14 | GHD-140-4D-FC20-Q04A | 14 | 20 | 25 | 50 | 74 | 58 | 124 | ● | QPMG040204 |
| Φ 15 | GHD-150-4D-FC20-Q04A | 15 | 20 | 25 | 50 | 80 | 62 | 130 | ● | |
| Φ 16 | GHD-160-4D-FC20-Q05A | 16 | 20 | 25 | 50 | 84 | 66 | 134 | ● | QPMG050204 |
| Φ 17 | GHD-170-4D-FC25-Q05A | 17 | 25 | 32 | 56 | 88 | 70 | 144 | ● | |
| Φ 18 | GHD-180-4D-FC25-Q05A | 18 | 25 | 32 | 56 | 95 | 75 | 151 | ● | QPMG060204 |
| Φ 19 | GHD-190-4D-FC25-Q06A | 19 | 25 | 32 | 56 | 99 | 79 | 155 | ● | |
| Φ 20 | GHD-200-4D-FC25-Q06A | 20 | 25 | 32 | 56 | 103 | 83 | 159 | ● | |
| Φ 21 | GHD-210-4D-FC25-Q06A | 21 | 25 | 32 | 56 | 107 | 87 | 163 | ● | |
| Φ 22 | GHD-220-4D-FC25-Q06A | 22 | 25 | 32 | 56 | 111 | 91 | 167 | ● | QPMG07T306 |
| Φ 23 | GHD-230-4D-FC25-Q07A | 23 | 25 | 32 | 56 | 115 | 95 | 171 | ● | |
| Φ 24 | GHD-240-4D-FC25-Q07A | 24 | 25 | 32 | 56 | 119 | 99 | 175 | ● | |
| Φ 25 | GHD-250-4D-FC25-Q07A | 25 | 25 | 32 | 56 | 123 | 103 | 179 | ● | |
| Φ 26 | GHD-260-4D-FC32-Q07A | 26 | 32 | 42 | 60 | 133 | 108 | 193 | ● | QPMG09T308 |
| Φ 27 | GHD-270-4D-FC32-Q07A | 27 | 32 | 42 | 60 | 137 | 112 | 197 | ● | |
| Φ 28 | GHD-280-4D-FC32-Q09A | 28 | 32 | 42 | 60 | 141 | 116 | 201 | ● | |
| Φ 29 | GHD-290-4D-FC32-Q09A | 29 | 32 | 42 | 60 | 145 | 120 | 205 | ● | |
| Φ 30 | GHD-300-4D-FC32-Q09A | 30 | 32 | 42 | 60 | 149 | 124 | 209 | ● | QPMG110408 |
| Φ 31 | GHD-310-4D-FC32-Q09A | 31 | 32 | 42 | 60 | 153 | 128 | 213 | ● | |
| Φ 32 | GHD-320-4D-FC32-Q09A | 32 | 32 | 42 | 60 | 157 | 132 | 217 | ● | |
| Φ 33 | GHD-330-4D-FC40-Q09A | 33 | 40 | 48 | 60 | 161 | 136 | 221 | ● | |
| Φ 34 | GHD-340-4D-FC40-Q11A | 34 | 40 | 48 | 70 | 169 | 141 | 239 | ● | QPMG110408 |
| Φ 35 | GHD-350-4D-FC40-Q11A | 35 | 40 | 48 | 70 | 173 | 145 | 243 | ● | |
| Φ 36 | GHD-360-4D-FC40-Q11A | 36 | 40 | 48 | 70 | 177 | 149 | 247 | ● | |
| Φ 37 | GHD-370-4D-FC40-Q11A | 37 | 40 | 48 | 70 | 181 | 153 | 251 | ● | |
| Φ 38 | GHD-380-4D-FC40-Q11A | 38 | 40 | 48 | 70 | 185 | 157 | 255 | ● | |
| Φ 39 | GHD-390-4D-FC40-Q11A | 39 | 40 | 48 | 70 | 189 | 161 | 259 | ● | |
| Φ 40 | GHD-400-4D-FC40-Q11A | 40 | 40 | 48 | 70 | 193 | 165 | 263 | ● | |

●标准库存 Stock ○需预定 Order



【配件】 Spare Parts

| 刀片型号 Insert Type | | 螺钉 Screw | | 扳手 Wrench | | 扭矩值 N · m |
|---|--------------|---|----------------------|--|----------------------|-----------|
| | | 型号 Type | 订货号 Ordering Code | 型号 Type | 订货号 Ordering Code | |
|  | |  | |  | | |
| QPMG040204 | SI60M2*4.3 | 730100961310 | T06 | 720309000975 | 0.6 | |
| QPMG050204 | SI60M2.2*5 | 730100961313 | T07 | 720300960507 | 0.8 | |
| QPMG060204 | SI60M2.2*5 | 730100961313 | T07 | 720300960507 | 0.8 | |
| QPMG07T306 | SI60M2.5*6.5 | 730100961043 | T07 | 720300960507 | 0.8 | |
| QPMG09T308 | SI60M3*7.2 | 730100961071 | T09 | 720300960237 | 1.2 | |
| QPMG110408 | SI60M4*9 | 730100961360 | T15 | 720300960232 | 2.0 | |



【推荐切削参数】 Recommended Cutting Data

| 工件材料 Workpiece Materials | 材料硬度 Materials Hardness (HB) | 切削速度 Vc Recommended Cutting Speed (m/min) | 进给 (mm/rev) *参考钻头直径* Feed (mm/rev)*Refer to Diameter Range * | | | | |
|-----------------------------|---|--|---|-------------|-------------|-------------|-----------|
| | | | 14.0 – 22.5 | 23.0 – 27.0 | 27.5 – 33.0 | 33.5 – 40.0 | |
| P | 低碳钢 Low Carbon Steel | 80 – 170 | (240) 160 – 300 | 0.04-0.06 | 0.04-0.06 | 0.04-0.08 | 0.04-0.08 |
| | 高碳钢 High Carbon Steel | 170 – 250 | (180) 140 – 220 | 0.04-0.10 | 0.04-0.12 | 0.06-0.16 | 0.08-0.18 |
| | 低合金钢 Low Alloy Steel | 140 – 260 | (180) 160 – 250 | 0.04-0.10 | 0.06-0.12 | 0.08-0.16 | 0.08-0.18 |
| | 高合金钢 High Alloy Steel | 180 – 300 | (160) 140 – 200 | 0.04-0.10 | 0.06-0.12 | 0.08-0.16 | 0.08-0.18 |
| | 铸钢 Cast Steel | 180 – 300 | (160) 140 – 200 | 0.05-0.08 | 0.06-0.12 | 0.08-0.14 | 0.08-0.16 |
| M | 铁素体/马氏体 不锈钢 (Fer/Mar)Stainless Steel | 150 – 270 | (180) 140 – 250 | 0.04-0.10 | 0.06-0.12 | 0.06-0.14 | 0.06-0.16 |
| | 奥氏体 Austenitic | 150 – 270 | (180) 150 – 250 | 0.04-0.10 | 0.06-0.12 | 0.06-0.14 | 0.06-0.16 |
| K | 可锻铸铁 Forged cast iron | 150 – 230 | (180) 120 – 220 | 0.04-0.10 | 0.06-0.14 | 0.06-0.16 | 0.08-0.2 |
| | 灰口铸铁 Gray cast iron | 150 – 230 | (200) 160 – 250 | 0.04-0.10 | 0.06-0.14 | 0.06-0.16 | 0.08-0.2 |
| | 球墨铸铁 Nodular cast iron | 160 – 260 | (180) 150 – 220 | 0.04-0.12 | 0.06-0.16 | 0.08-0.18 | 0.08-0.2 |
| S | 镍基/铁基/钴基 耐热合金 (Ni+/Fe+/Co+)HRSA | 130 – 400 | (50) 30 – 80 | 0.04-0.06 | 0.04-0.08 | 0.04-0.10 | 0.06-0.12 |
| | Ti 基+耐热合金 (Ti+)HRSA | 130 – 400 | (50) 30 – 70 | 0.04-0.08 | 0.04-0.10 | 0.06-0.12 | 0.08-0.11 |
| H | 淬硬钢 Hardened Steel | 400 – | (45) 30 – 60 | 0.04-0.08 | 0.04-0.10 | 0.06-0.12 | 0.08-0.14 |



● SPMG 钻削刀片 SPMG Drilling Insert



【特点】 Features

- 四条切削刃，经济性好
Four cutting edge, better economy
- 内外刀片共用、管理方便
- Both the central and the outside inserts are the same, more convenient for management
- 适合多种材质加工，通用性好
- Fitting for various materials

【刀片规格】 Insert List

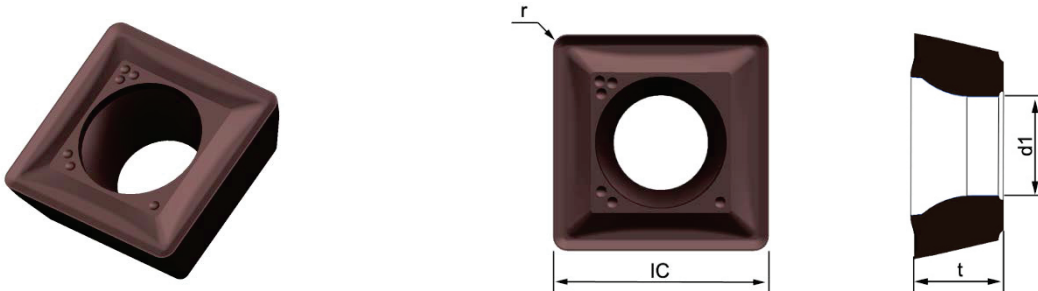

| 型号 Type | 材质 Grade | 尺寸 (Dimension) | | | | 钻孔直径 Dia of Drill | 库存 Stock |
|---------------|-------------|----------------|------|-----|------|----------------------|-------------|
| | | IC | t | r | d1 | | |
| SPMG050204-DM | A4230 | 5 | 2.38 | 0.4 | 2.2 | Φ 13.0~ Φ 15.0 | ● |
| SPMG060204-DM | A4230 | 6 | 2.38 | 0.4 | 2.6 | Φ 15.5~ Φ 21.5 | ● |
| SPMG07T308-DM | A4230 | 7.94 | 3.97 | 0.8 | 2.8 | Φ 22.0~ Φ 27.5 | ● |
| SPMG090408-DM | A4230 | 9.8 | 4.3 | 0.8 | 4.23 | Φ 28.0~ Φ 33.0 | ● |
| SPMG110408-DM | A4230 | 11.5 | 4.76 | 0.8 | 4.4 | Φ 33.0~ Φ 41.0 | ● |
| SPMG140512-DM | A4230 | 14.3 | 5.2 | 1.2 | 5.75 | Φ 42.0~ Φ 50.0 | ● |

● 标准库存 Stock ○ 需预定 Order